

Argosy Dishcloth

By Vyvyan Neel

<http://inahappycamper.eponym.com/blog>



My inspiration for this dishcloth came after seeing so many beautiful versions of the Argosy scarf online. You guys are so creative! I've seen them expanded in width, using hand-dyed hand-spun yarn and I've even seen a baby blanket in the works. Thanks to everyone who has complimented on the pattern.

This is a quick & fun project. Keep in mind that it will not be square in shape but more of a parallelogram. It has an almost "quilty", slightly corrugated look to it before washing.

Coming soon to my blog, I will be creating a whole page with free patterns featuring the Argosy "theory" interpreted in a wrap (rectangular), shawl (triangular) and a baby blanket (thanks to Kay @ MDK). Check back for them later.

If you have any problems or find errors with the instructions please notify me and I'll try to get them worked out as soon as I can.

Email me at: vyvneel@sbcbglobal.net

Materials:

- Peaches & Creme 100% cotton 2 oz. 1 skein color: 175 Fiesta Ombre
- US #7 (4.5 mm) needles

*Gauge is not critical for this design

Finished size: 14.5 inches long by 11 inches wide

Abbreviations:

K = Knit

P = Purl

SSK = slip, slip, knit these 2 sts together

K2tog = knit 2 sts together

YO = yarn over

CO = cast on

St = stitch

RS = right side

WS = wrong side

PATTERN NOTES

Note 1: When casting on, always use the Knitted-On Cast On method. Note that this is different from the original Argosy pattern published on Knitty.com.

Note 2: Chart provided for additional reference.

Note 3: Odd-numbered rows are RS rows & even-numbered rows are WS rows.



Close-up

Argosy Dishcloth

By Vyvyan Neel

<http://inahappycamper.eponym.com/blog>

WRITTEN DIRECTIONS:

CO 9 sts.

Row 1, 2, 4, 6, & 8: K1, p7, k1.

Row 3, 5 & 7: K1, yo, k2tog, k3, ssk, yo, k1.

Row 9: K1, yo, k2tog, k3, ssk, yo, k1, CO 8 sts (17 sts).

Row 10: [K1, p7] 2 times, k1, CO 8 sts (25 sts).

Row 11 & 12: [K1, p7] 3 times, K1.

Row 13 & 15: K1, yo, k2tog, [k3, ssk, yo, k1, yo, k2tog] 2 times, k3, ssk, yo, k1.

Row 14 & 16: [K1, p7] 2 times, k1.

Row 17: K1, yo, k2tog, [k3, ssk, yo, k1, yo, k2tog] 2 times, k3, ssk, yo, k1, CO 8 sts (33 sts).

Row 18: [K1, p7] 4 times, k1, CO 8 sts (41 sts).

Row 19 & 20: [K1, p7] 5 times, k1.

Row 21 & 23: K1, yo, k2tog, [k3, ssk, yo, k1, yo, k2tog] 4 times, k3, ssk, yo, k1.

Row 22 & 24: [K1, p7] 5 times, k1.

Row 25: K1, yo, k2tog, [k3, ssk, yo, k1, yo, k2tog] 4 times, k3, ssk, yo, k1, CO 8 sts (49 sts).

Row 26: [K1, p7] 6 times, k1, CO 8 sts (57 sts).

Row 27 & 28: [K1, p7] 7 times, k1.

Row 29 & 31: K1, yo, K2tog, [k3, ssk, yo, k1, yo, k2tog] 6 times, k3, ssk, yo, k1.

Row 30 & 32: [K1, p7] 7 times, k1.

Row 33: K1, yo, k2tog, [k3, ssk, yo, k1, yo, k2tog] 6 times, k3, ssk, yo, k1, CO 8 sts (65 sts).

Row 34: [K1, p7] 8 times, k1, CO 8 sts (73 sts).

Row 35 & 36: [K1, p7] 9 times, k1.

Row 37, 39 & 41: K1, yo, k2tog, [k3, ssk, yo, k1, yo, k2tog] 8 times, k3, ssk, yo, k1.

Row 38, 40, 42 & 43: [K1, p7] 9 times, k1.

Row 44: [P2tog, slip st back to left needle] 7 times, p2tog, [p7, k1] 8 times (65 sts).

Row 45: [K2tog, slip st back to left needle] 8 times, k2tog, yo, k4, ssk, yo, [k1, yo, k2tog, k3, ssk, yo] 6 times, k1 (57 sts).

Row 46, 48, 50 & 51: [K1, p7] 7 times, k1.

Row 47 & 49: [K1, yo, k2tog, k3, ssk, yo] 7 times, k1.

Row 52: [P2tog, slip st back to left needle] 7 times, p2tog, [p7, k1] 6 times (49 sts).

Row 53: [K2tog, slip st back to left needle] 8 times, k2tog, yo, k4, ssk, yo, [k1, yo, k2tog, k3, ssk, yo] 4 times, k1 (41 sts).

Row 54, 56, 58 & 59: [K1, p7] 5 times, k1.

Row 55 & 57: [K1, yo, k2tog, k3, ssk, yo] 5 times, k1.

Row 60: [P2tog, slip st back to left needle] 7 times, p2tog, [p7, k1] 4 times (33 sts).

Row 61: [K2tog, slip st back to left needle] 8 times, k2tog, yo, k4, ssk, yo, [k1, yo, k2tog, k3, ssk, yo] 2 times, k1 (25 sts).

Row 62, 64, 66 & 67: [K1, p7] 3 times, k1.

Row 63 & 65: [K1, yo, k2tog, k3, ssk, yo] 3 times, k1.

Row 68: [P2tog, slip st back to left needle] 7 times, p2tog, [p7, k1] 2 times (17 sts).

Row 69: [K2tog, slip st back to left needle] 8 times, k2tog, yo, k4, ssk, yo, k1. (9 sts).

Row 70, 72, 74 & 75: K1, p7, k1.

Row 71 & 73: K1, yo, k2tog, k3, ssk, yo, k1.

Row 76: [P2tog, slip st back to left needle] 7 times, p2tog. Break yarn, draw through last st and pull tight.



Pattern & Images © 2007 Vyvyan Neel

All rights reserved. Pattern is for personal use only. It is not to be sold or used to produce garments for resale. It may not be reprinted on the web or otherwise without permission. <http://inahappycamper.eponym.com/blog>

Argosy Dishcloth Chart

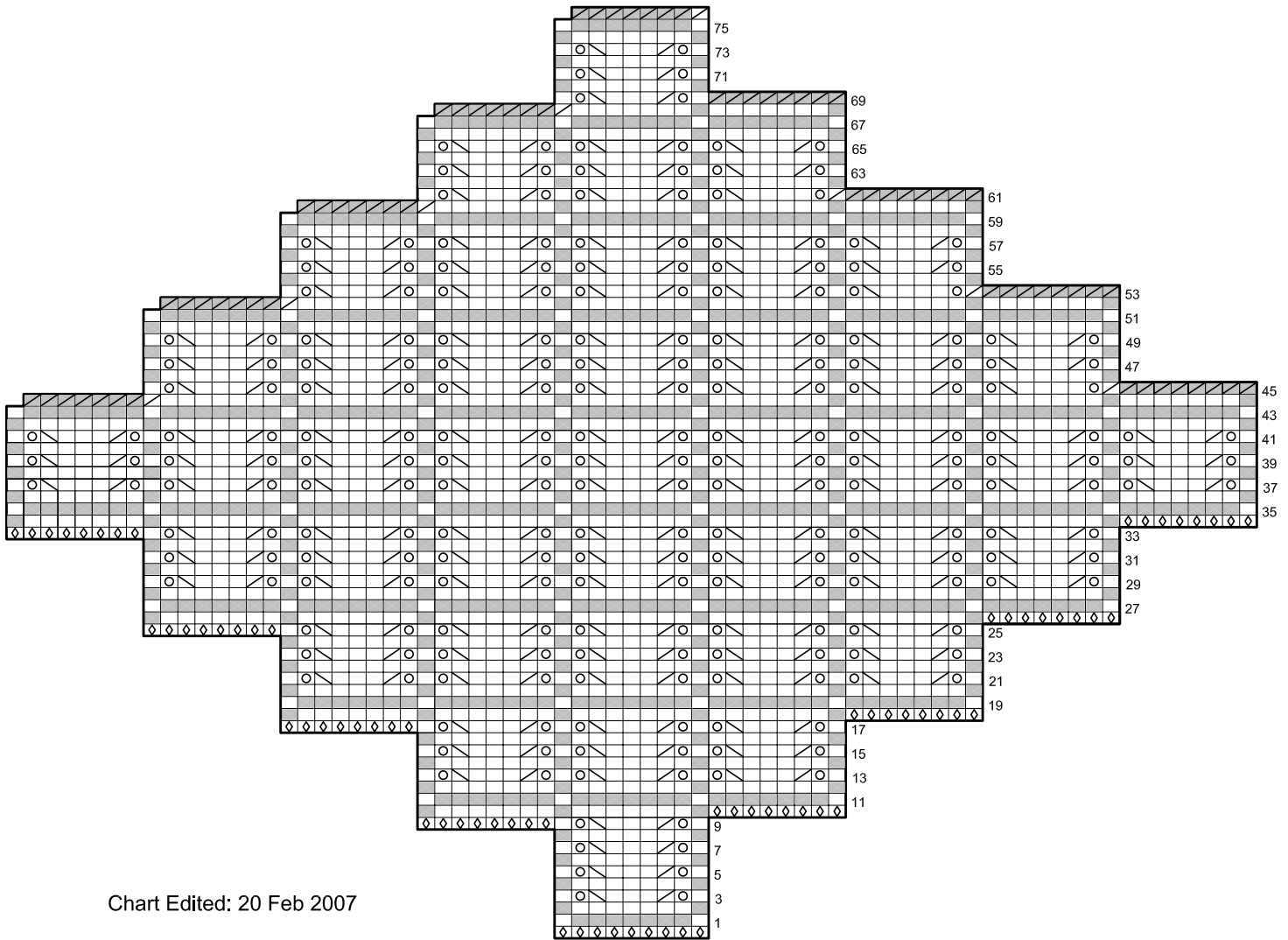
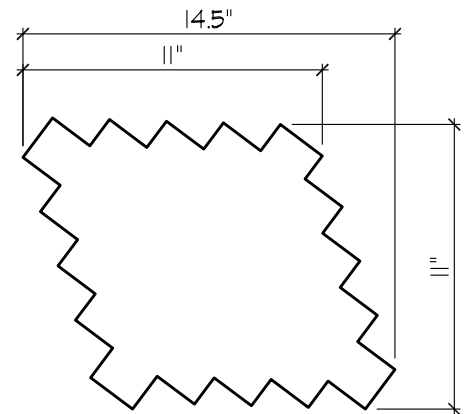

Chart Edited: 20 Feb 2007

Chart Key		
	CO 1 st	
	Yarn Over	
	K2tog	
	Ssk	
	K2tog on RS, P2tog on WS; slip stitch back to left needle	
	P on RS, K on WS	
	K on RS, P on WS	



Schematic

Pattern & Images © 2007 Vyvyan Neel
 All rights reserved. Pattern is for personal use only.
 It is not to be sold or used to produce garments for resale. It may not be
 reprinted on the web or otherwise without permission.
<http://inahappycamper.eponym.com/blog>